



350 W



RASOR
RASOR ELETTROMECCANICA S.R.L.
Via V. Caldesi 6 - 20161 Milan - Italy
ph. +39 02 66221231 - fax +39 02 66221293
Customer service: info@rasor-cutters.com
www.rasor-cutters.com
Rasor Copyright

MONSTER

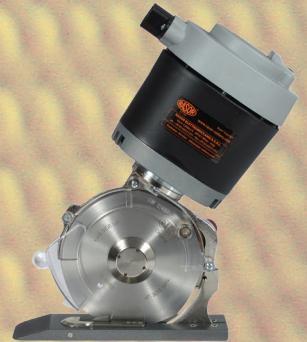

AVAILABLE IN
RIGHT VERSION
SW12SM



SW12SSM MONSTER ELECTRIC CUTTING UNIT



1946

SW12SSM. The most powerful cutting unit for Technical Textile & Composite.



ELECTRIC CUTTING UNIT SW12SSM



WHAT'S NEW:

- New 350 W heavy duty motor
- Extra strong torque optimized steel/brass gears
- Central knife guidance
- New main power switch with Led
- Easy fixing structure for O.E.M applications
- Low-friction Teflon® coated foot

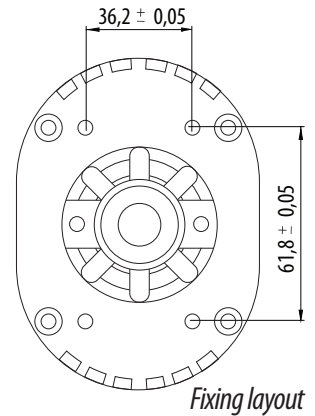

TECHNICAL DETAILS:

- Blade diameter:** 120 mm (4.7"), with hard metal counterblade
- Blade equipped:** 12SHSS, 8-edges, HSS steel
- Blade speed:** 550 r.p.m.
- Cutting ability:** up to 50 mm (2")
- Power:** single phase – 350 W
- Max. absorption:** 2.5 A
- Net weight:** 3300 g (with power supply cord)
- Total weight (with packing box):** 5500 g
- Electric cable length:** 1.5 mt (with no plug)
- Minimum brightness for working operations:** LUX 200
- Vibrations at start up:** < 2.5 m/sec 2
- Temperature range:** 0 – 55 C
- Umidity range:** 10 – 95% without condensate

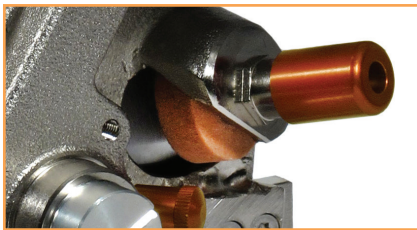

Dimension layout

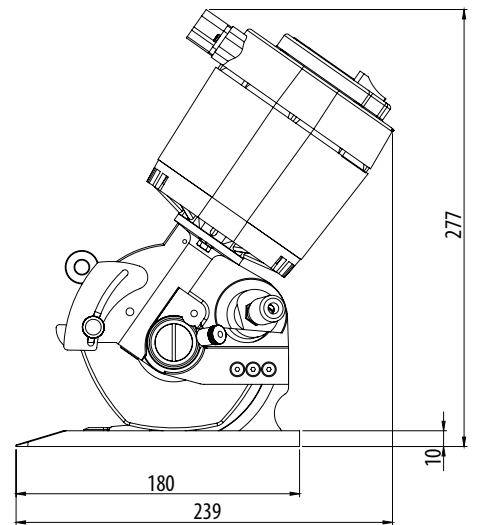

BLADES AVAILABLE:

12SHSS, 120 mm 8-edges, HSS steel | **12CHSS**, 120 mm circular, HSS steel | **12DHSS**, 120 mm 12-edges, HSS steel | **12SHSSTF**, 120 mm 8-edges, HSS steel Teflon® coated | **12SHSSTN**, 120 mm 8-edges, HSS steel Titanium coated | **12DHSSTN**, 120 mm 12-edges, HSS steel Titanium coated | **12SMD**, 120 mm 8-edges, Carbide (Widia®)



PETRONI SRL
Via A.Bucchi, 1/B
06012 Città di Castello (PG)

+39 075/852.07.87

www.petronisrl.it